

## TekSpan® T-Lock Bolt

Product Code: R951-510

### Description

10.9g T-Bolt with locking washer - locks securely through profile slots with locating collar and "bites" into bracket fixture, providing exceptional joint strength.

### Technical Details

Pack Qty	50
Weight	0.120kg/st
Material	Steel
Finish	Zinc-Nickel
Strength Class	10.9
Max load Fx - 100mm Profile	10kN
Max load Fy - 100mm Profile	10kN
Max load Fz - 100mm Profile	3kN
Max load Fx - 80mm Profile	8kN
Max load Fy - 80mm Profile	8kN
Max load Fz - 80mm Profile	3kN
Thread	M12
Length thread	40mm
Tightening torque - 100mm Profile	120Nm
Tightening torque - 80mm Profile	90Nm
Overall length	34mm
Width hammer head	12.5mm
Diameter washer	23.5mm
Length hammer head	28mm
Thickness hammer head	12mm
Thickness washer	10mm
Profile types	80mm / 100mm

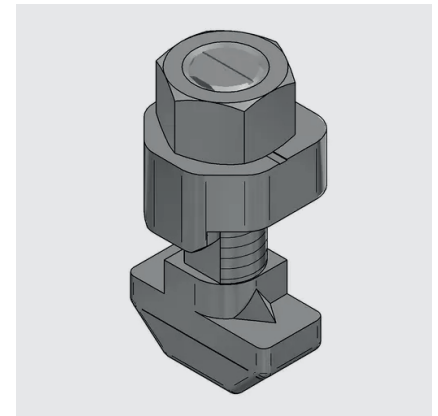

### Data Centre Compatibility

No whisker formation occurs with the zinc-nickel bolt. In contrast to pure zinc coatings, there is no whisker formation when zinc-nickel is deposited as an alloy and intermetallic phase.

This has been tested using parts with the acidic zinc-nickel electrolyte used. The zinc-nickel parts were provoked with several influencing factors and no whiskers could be detected at any time.

Zinc-nickel coated parts are therefore highly suitable for use in data centres.

### Certifications

