

M10 BZP Hollow Core Slab Ceiling Anchor - ETA Approved

Product Code: B331-550

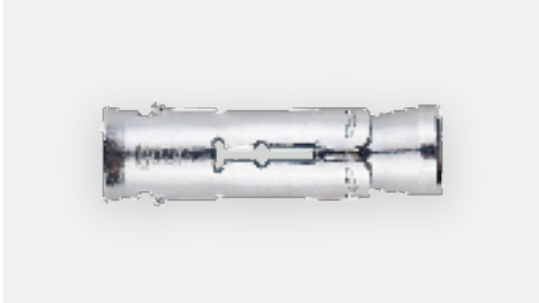

- European approval for interior non-structural applications in hollow slabs
- CE Certification
- R60 to R120 Fire Approval
- Flare collar prevents the anchor from entering the hole, making installation straightforward
- Suitable for installations with reduced distances
- Suitable for use with bolts or threaded rod

Specification

Drill bit diameter (d_0)	16mm
Drill hole depth (h_1)	60mm
Anchor plate diameter (d_f)	12mm
Installation torque (T_{ins})	30 Nm
Installation depth \geq (h_{nom})	53mm
Minimum bolt length (e)	$t_{fix} + 55\text{mm}$
Minimum spacing	100mm
Minimum edge distance	90mm
Critical spacing between anchors	200mm
Critical edge distance	100mm
Box quantity	25

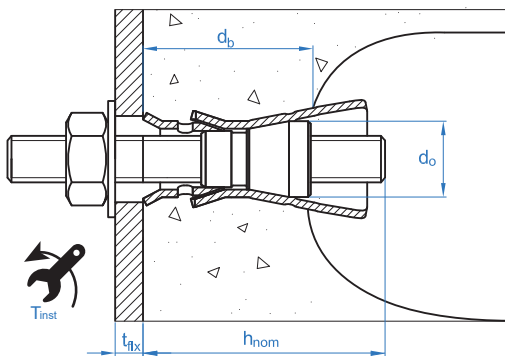

Applications

- Suspended ceiling fixings
- Sprinkler systems and ventilation systems
- Pipe work installations
- Cable ducts
- Suspended ceiling

Installation

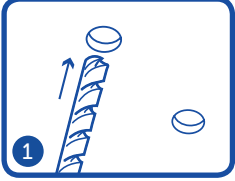
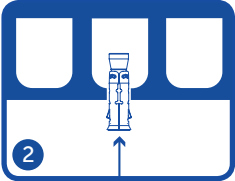
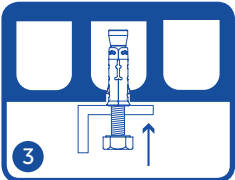
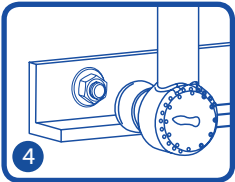
	<p>1. DRILLING Check concrete is well compacted and porosity is insignificant. Suitable for dry, humid or flooded drillholes. Drill using percussion or hammer setting. Drill to the specified diameter depth.</p>
	<p>2. INSTALL Insert the anchor to the bottom of the drillhole. Use hammer if necessary. The anchor must be flush to the surface of the base material.</p>
	<p>3. PLACE MATERIAL TO BE FIXED Place the material to be fixed, threading the bolt or stud through the drillhole. Use the required bolt length. The use of wide series of washer (DIN 9021) is recommended. Do not apply any type of intermediate layer (sealants, etc.) between the material to be fixed and the washer.</p>
	<p>4. APPLY THE TORQUE Apply nominal torque using a torque wrench.</p>

Base material



Hollow-core slab

Material	Coating
<p style="text-align: center;">A</p> <p style="text-align: center;">Carbon Steel</p>	<p style="text-align: center;">Z ZINC</p> <p style="text-align: center;">Zinc-plated $\geq 5\mu\text{m}$</p>

Approval



Application examples



Resistances

Characteristic resistance for non-structural applications in hollow concrete slabs type $d_b \geq 25; < 30$ mm with minimum thickness of 30 mm and for an isolated anchor (without consideration of edge distance or distances between anchors), with bolt class 6.8.

ETE 15/0912 Approval		Yes
Characteristic resistance in hollow concrete slabs \geq C40/50 (F_{Rk})	$d_b \geq 25; < 30$ mm	8.0kN
	$d_b \geq 30; < 40$ mm	14.0kN
	$d_b \geq 40$ mm	14.0kN
Partial safety coefficient		1,8

1kN \approx 100 kg

The safe load recommended $\gamma_F = 1,4$

Calculation example:

Fixing a 400kg tensile load (= 3,92 kN) on a C40/50 hollow concrete slab with 43mm thickness with an HC10 anchor and bolt class 6.8

Verification to be performed: Load calculation < Resistance of calculation

Load calculation = service load * safe load coefficient = 3,92 * 1,4 = 5,49 kN

Resistance of calculation = characteristic resistance / partial safety coefficient = 14,0 / 1,8 = 7,78 kN

Verification: 5.49 kN < 7,78 kN: the fixing is safe.